

Color Sensors Light-To-Digital

www.ams.com/TCS3472



TCS3472 – Color Sensor Family

- RGB color light sensing with integrated IR-blocking filter
- Ideal solution for use under varying lighting conditions and through attenuating materials
- Enables accurate color temperature and ambient light sensing for display-based products

We provide innovative analog solutions to the most challenging applications in sensor and sensor interfaces, power management, and wireless.

General Description

The TCS3472 device family provides digital red, green, blue and clear (RGBC) color light sensing. It includes an IR-blocking filter to minimize effects of the IR spectral component in light and produce accurate color measurements. The IR-blocking filter is integrated directly on-chip and localized to the color sensing photodiodes. The high sensitivity, wide dynamic range, and IR-blocking filter make the TCS3472 an ideal solution to use under varying lighting conditions and through attenuating materials. The color sensing has a wide range of applications, including RGB LED backlight control, solid-state lighting,

health/fitness products, industrial process controls, and medical diagnostic equipment. In addition, the IR-blocking filter enables the TCS3472 to perform ambient light sensing. Ambient light sensing is widely used in display-based products, such as mobile phones, notebooks, tablets and TVs, to sense the lighting environment and enable automatic display brightness for optimal viewing and power savings. In low-power applications, the TCS3472 can enter a lower-power wait-state between RGBC measurements to reduce the average power consumption.

Applications

- Light Color Temperature Measurement and Control
- RGB LED Backlight Control
- Ambient Light Sensing for Display Brightness Control
- Industrial Process Control
- Medical Diagnostics

Features

- Color Light Sensing with IR-blocking filter
 - 3.8M:1 dynamic range
 - very high sensitivity
 - programmable analog gain and integration time
- Power Management
 - 65 μ A typical current
 - programmable wait timer
- I²C fast-mode compatible interface
 - 400 kbits/s data rate
 - V_{DD} or 1.8-V Bus interface
- 2 x 2.4 mm Dual Flat No-Lead (FN) Package

Device	Package	I ² C Interface		Ordering Number
		Address ¹	Bus Voltage	
TCS34725	FN-6	0X29	V _{DD}	TCS34725FN
TCS34727	FN-6	0X29	1.8V	TCS34727FN

¹ Alternate address option available

TCS3472 Block Diagram

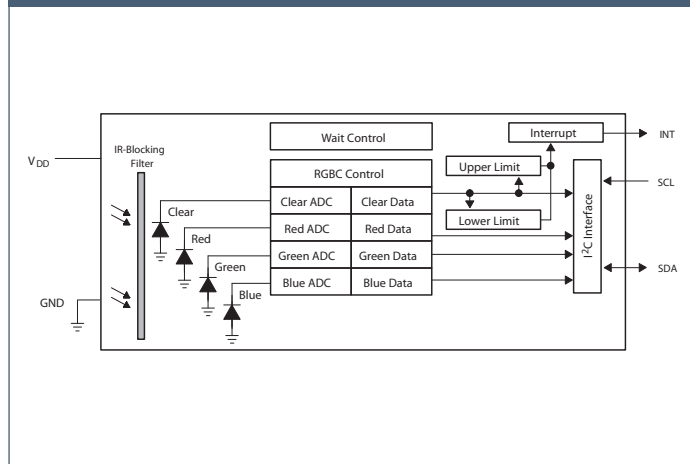

Photodiode Spectral Responsivity

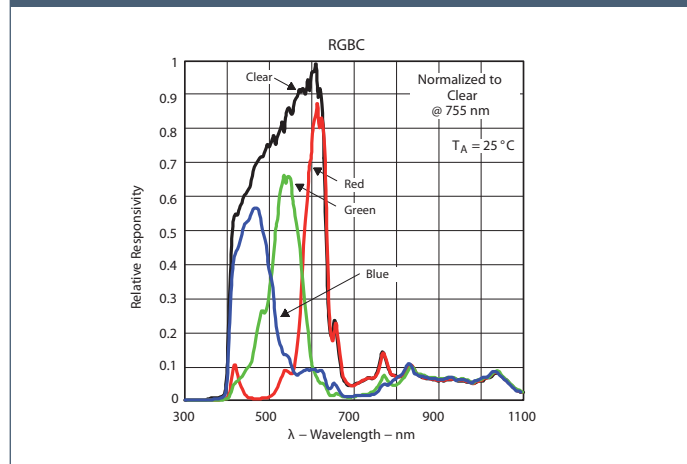

www.ams.com
 products@ams.com
 © 11/2012 by ams
 Subject to change without notice

AMS-TAOS USA Inc.
 1001 Klein Road, Suite 300
 Plano, TX 75074, USA
 Phone: +1 972 673 0759



Sales Offices Worldwide
 sales-europe@ams.com
 sales-asia@ams.com
 sales-americas@ams.com